

# 8520/8520R

## User Manual

### *Warranty*

All products manufactured by SuperLogics are warranted against defective materials for a period of one year from the date of delivery to the original purchaser.

### *Disclaimer*

SuperLogics assumes no liability for damages consequent to the use of this product. SuperLogics reserves the right to change this manual at any time without notice. The information furnished by SuperLogics is believed to be accurate and reliable. However, no responsibility is assumed by SuperLogics for its use, nor for any infringement of patents or other rights of third parties resulting from its use.

### *Copyright*

Copyright 1999 by SuperLogics. All rights reserved.

### *Trademarks*

Trademarks and tradenames used herein are the property of their respective owners.

### *License*

This software may be used, modified or backed-up on a single machine. The software, or any copy of it, may not be reproduced, transferred, or distributed, in whole or in part.

# Table of Contents

---

## ***Chapter 1 Introduction***

1.1 8000 Series Overview .....	3
1.2 8000 Series Common Features .....	4
1.3 8000 System Network Configuration .....	5
1.4 8000 Series Module Dimensions .....	8

## ***Chapter 2 8520 / 8520R Specifications***

2.1 Pin Assignments .....	11
2.2 Specifications .....	12
2.3 Block Diagram .....	13
2.4 Basic Wire Connections .....	14
2.5 Choosing between the 8520 and 8520R .....	15

## ***Chapter 3 8000 RS-485 Networks***

3.1 Standard & Isolation Configurations .....	19
3.2 PLC Networking Applications .....	22
3.3 PC Networking Applications .....	23
3.4 Using RS-232 Devices in a 8000 Network .....	24

# Introduction

---

The 8000 Series of modules is comprised of analog and digital I/O modules designed for a wide variety of data acquisition and signal conditioning functions. These modules are designed for an RS-485 communication network, and require an RS-485 to RS-232 converter in order to be accessed through a standard PC serial port. The 8520/8520R module performs this function. Unlike many other converters, the versatile 8520 contains a unique self-tuner AISC that allows it to process signals from multiple serial devices operating at different baud rates and using different data formats. This flexibility makes a 8000 Series network an extremely cost effective solution for remote signal monitoring and control

## *1.1 Available 8000 Series Modules*

The 8000 Series is comprise of the following modules:

### **Bus Conversion and Repeater Modules:**

- 8520: RS-232 to RS-485 converter
- 8520R: RS-232 to RS-485 converter with 3000V isolation
- 8510: RS-485 to RS-485 repeater with 3000V isolation

### **Digital I/O Modules:**

- 8050: 7 digital input channels, 8 TTL compatible digital output channels
- 8052: 8 isolated digital input channels
- 8060: 4 isolated digital input channels, 4 digital relay outputs

### **Analog Output Modules:**

- 8021: Single channel analog (current or voltage) output

### **Analog Input Modules:**

- 8013D: Single channel RTD analog input
- 8014D: 1 channel analog input, 1 channel digital input, 2 channels digital output, with LED display.
- 8017: 8 channel analog input module
- 8018: 8 channel thermocouple input module

### **Timer/Counter Modules:**

- 8080D: 2 independent 32-bit counters, 2 digital output channels, 5Hz to 50Hz frequency measurement range.

## ***1.2 8000 Series Common Features***

### **Communication :**

- Asynchronous half-duplex 2-wire RS-485 network
- Maximum network distance without repeater=4000 feet (1.2Km)
- Baud Rates: 1200,2400,4800,9600,19200,38400,57600,115200 (bps)
- Up to 256 modules per 8520 converter or 2,048 modules in a network using 8510 repeaters
- A single network can accommodate multiple devices with different baud rates and data formats
- 8000 series data format=1 start + 8 data + 1 stop + no parity = 10-bit
- Two extra checksum bytes can be enabled or disabled
- Built-in transient voltage suppresser and PTC protector
- ASCII command/response protocol
- Plug-in screw terminal block

### **Power :**

- +10V ~ +30V DC
- Power reverse protection, over-voltage brown-out protection

### **System :**

- Internal Dual watchdog, power-on start value and safe value for host failure
- Operating temperature : -10 to 70°C (14 to 185°F)
- Storage temperature : -25 to 80°C (-13 to 185°F)
- Humidity : 5 to 95%, non-condensing
- Isolation voltage : 3000 VDC

# 1.3 8000 System Network Configuration

## Multiple Baud Rate & Multiple Data Format

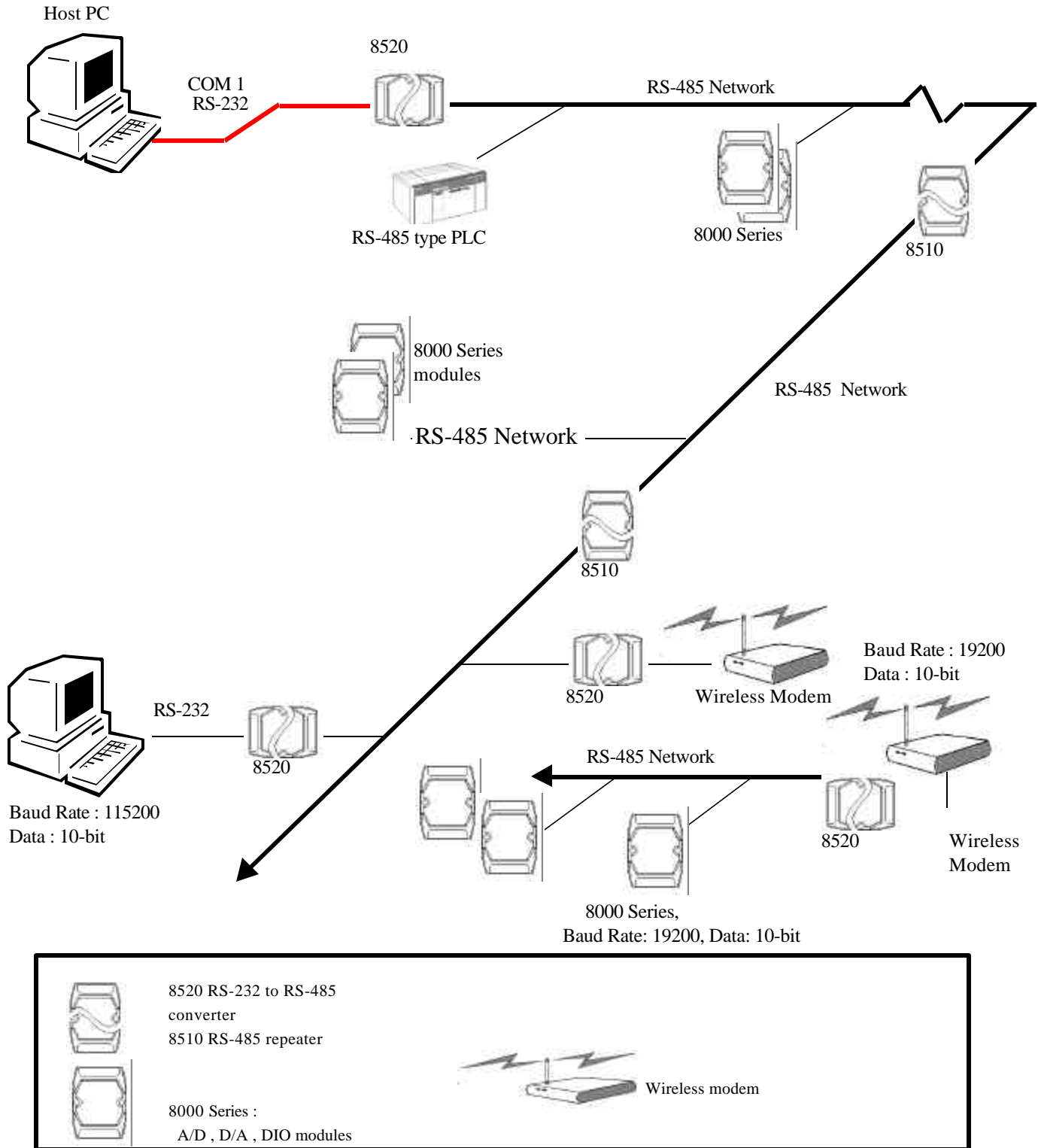

Figure 1.3.1 8000 Series Remote Data Acquisition and Signal Conditioning Network

### **Disadvantages of Conventional Two-Wire RS-485 Networks:**

In a standard RS-485 network, a converter is used to adapt the host PC's single wire RS-232 signal to the two-wire RS-485 signal required by the network. However, when using a standard converter, not only must the baud rate and data format for all signals remain fixed, but they must be identical for all incoming signals. This can pose a problem if multiple types of devices are to be used in a single system, such as a module operating at 115200 bps with a 10-bit per channel data format, and a standard PLC operating at 9600 bps with an 11-bit data format. One solution to this problem is to use two independent two-wire RS-485 networks to accommodate both devices. However, this can increase overall system cost and decrease system reliability. If devices are capable of operating at different baud rates, but share a single data format, a single standard two-wire RS-485 network can be used, provided that all devices are set to use the lowest common baud rate. While this solution may save on system cost, it is at the expense of performance.

### **The 8000 Series Network Advantage:**

The 8000 Series is a powerful two-wire RS-485 network which provides the flexibility of linking devices with multiple baud rates and data formats in a single system. The 8520 RS-232 to RS-485 converter, is equipped with a patent pending "Self Tuner" ASIC which can auto-tune the baud rates and data formats for an entire RS-485 network. It can also handle the direction of the RS-485 communication line. This is all done automatically without the inconvenience of manually setting DIP switches. This unique feature, which permits using a single host PC and a single communication line for up to 2,048 different devices, greatly reduces system cost and increases system reliability.

### **Operation Principle (Refer to *Figure 1.3.1*):**

- (1) The Host PC sends out a command via COM1.
- (2) The 8520 converts the RS-232 signal into a RS-485 signal.
- (3) All modules connected to the RS-485 network will simultaneously receive this command. Each module in the network will extract the destination address field and compare this value to its local module address.
- (4) The module to which the command was addressed will execute it, and the other modules will ignore the command.
- (5) After executing the command, the addressed module sends a response back to the host PC over the RS-485 network.
- (6) The 8520 module processes the response and converts it from RS-485 to RS-232 for use by the Host PC
- (7) Host PC will interpret this result and take appropriate action.

### **8510 Isolated Repeater:**

The 8510 repeater module is used to expand a standard RS-485 network. A single 8520 is capable of supporting a 256 module network over 4,000 feet. Each 8510 module can be used to extend the network by another 256 modules or another 4,000 feet. As a single 8520 can support eight 8510 repeaters, up to 2,048 individual modules can be connected in a single network. The 8510 repeater can also be used to partition a long RS-485 path into several shorter isolated paths, for safety considerations. (See the 8510 manual for more information on this module).

### **Supporting Multiple Baud Rates :**

As noted earlier, 8000 Series networks support devices operating at different baud rates. For example, in *Figure 1.3.1* the diagram depicts a wireless modem operating at 19200 bps, 8000 Series modules operating at 115,200 bps and a PLC operating at 9600 bps. The 8520 converter module can automatically switch to any baud rate in the 1200 bps to 115,200 bps range. When the host PC sends commands it tailors them to the baud rate at which the target module is operating. Any module set for a different baud rate will ignore the command, each module at the target baud rate will determine whether the command is addressed to it (see step 3 in section 1.2 above) and react appropriately.

### **Supporting Multiple Data Formats:**

As noted earlier, a SuperLogics 8000 Series Network can support multiple devices using different data formats because of the Self-Tuner ASIC on the 8520 module. For instance, a standard RS-232 serial signal takes the form of: START-bit+DATA-bit+PARITY-bit+STOP-bit. 8000 Series modules uses a 10 bit data format as follows: "1 START-bit+8 DATA-bit + no PARITY-bit + 1 STOP-bit." A standard PLC uses an 11-bit data format as follows: "1 START+7 DATA+1 PARITY+2 STOP." The Host PC can send and receive data in multiple formats, so the only restrictions are due to limitations of the serial network delivering the data. The 8520 module translates RS-485 signals from the network (which is made up of multiple 8000 Series modules, serial input devices, PLCs, or other PCs) into RS-232 for the host computer, while retaining the data format appropriate for each device. This feature, which permits accommodating so many different types of device on a single network, makes the 8000 Series an extremely cost-efficient choice.

### **Dual WatchDog:**

The 8000 series is designed for harsh environments and industrial applications. In such environments, there is bound to be a problem with noise and transient energy. If there is a very large amount of interference, it may cause problems in the 8000 modules. The watchdog timers are constantly monitoring the system to make sure that everything is functioning within acceptable parameters. The module (hardware) watchdog concerns itself with the individual modules, and if a problem is detected it can reset a single module without altering the entire network. The host (software)watchdog is responsible for the whole system, and will reset the entire network if problems are encountered.

When a problem is encountered in a single module it will revert to its predefined start value. If there is a network problem, all modules will revert to safe states. If the host-PC is down, all modules revert to their predefined safe states as a safety protection. **This dual watchdog system greatly increases system reliability, and greatly reduces the potential damage which could result from a system failure.**

## 1.4 8000 Series Module Dimensions

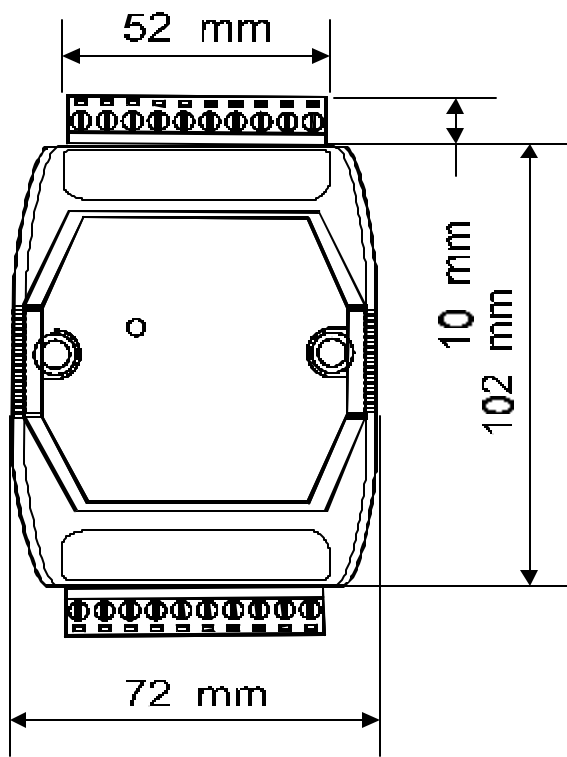

**FRONT VIEW**

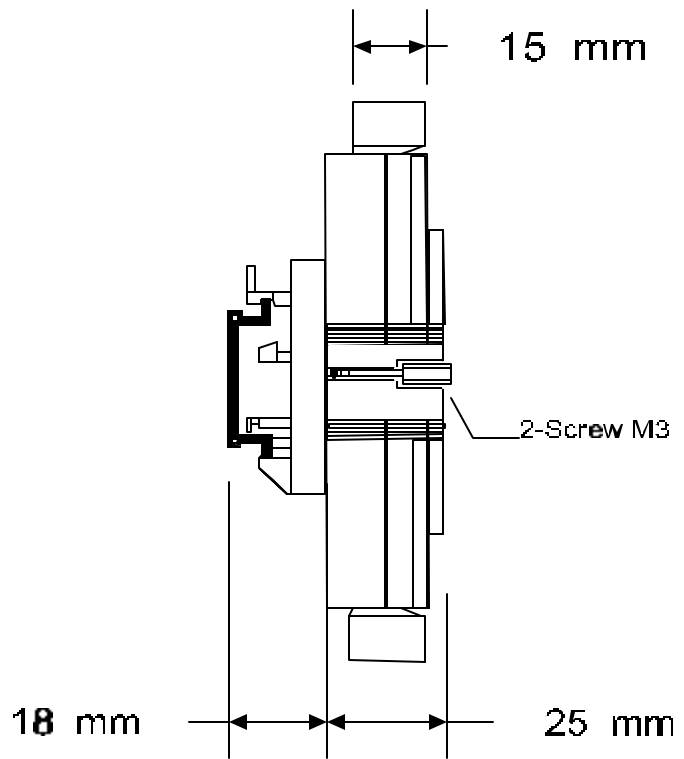

**SIDE VIEW**

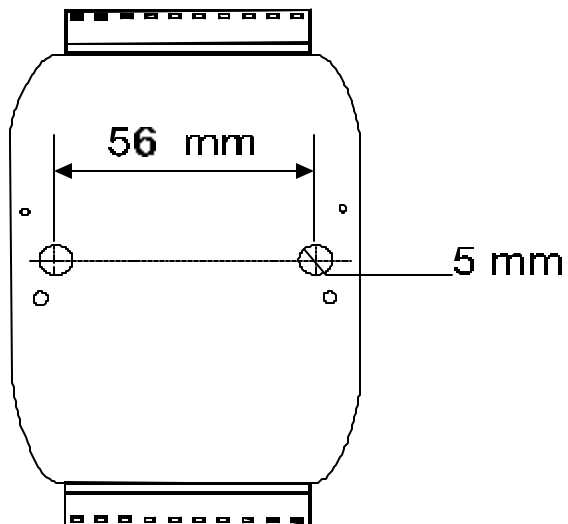

**REAR VIEW**

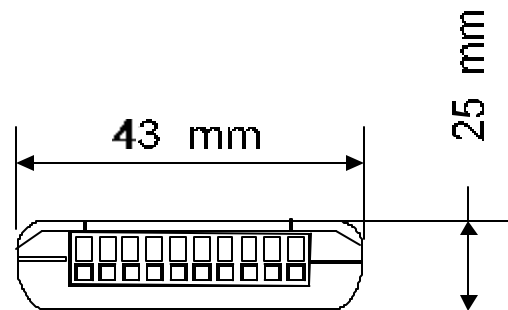

**TOP VIEW**

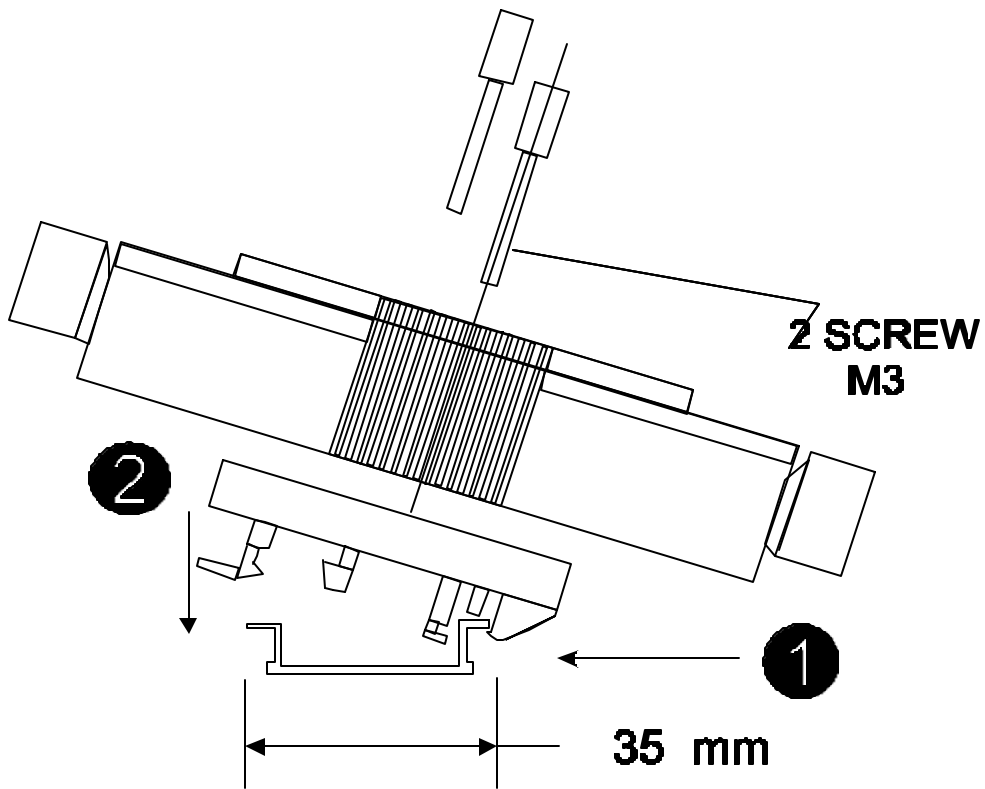

## DIN-RAIL Mounting

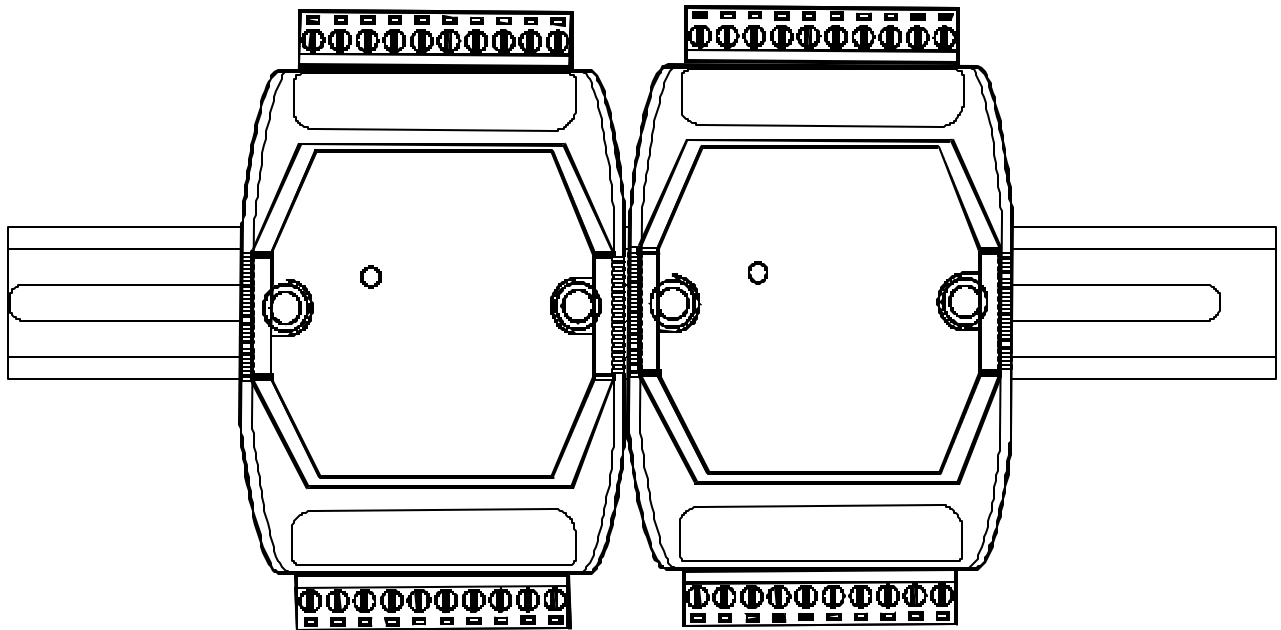

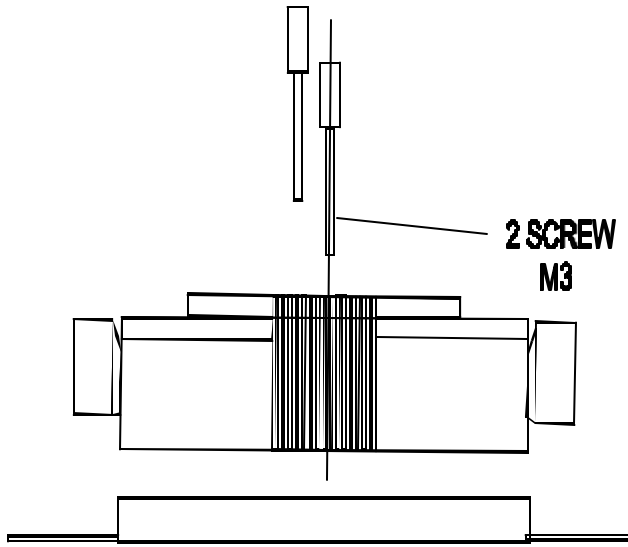

## Panel Mounting

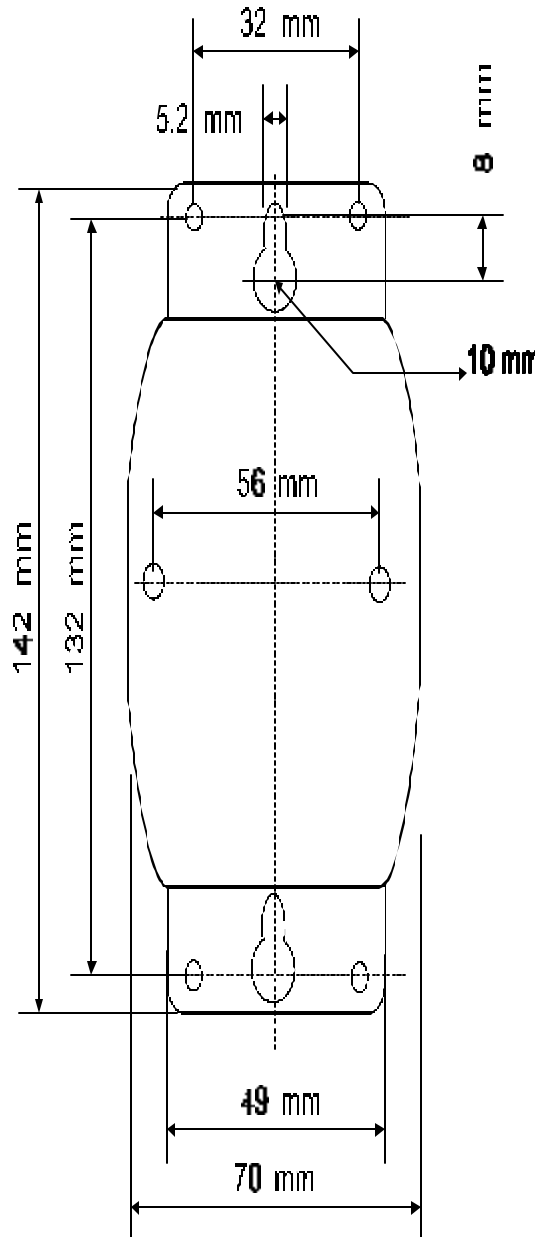
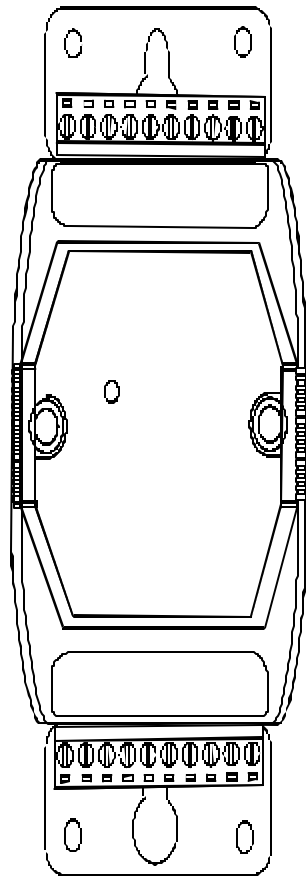

## *Plastic Part for Panel Mount*

# 8520 / 8520R Specifications

---

## 2.1 Pin Assignments

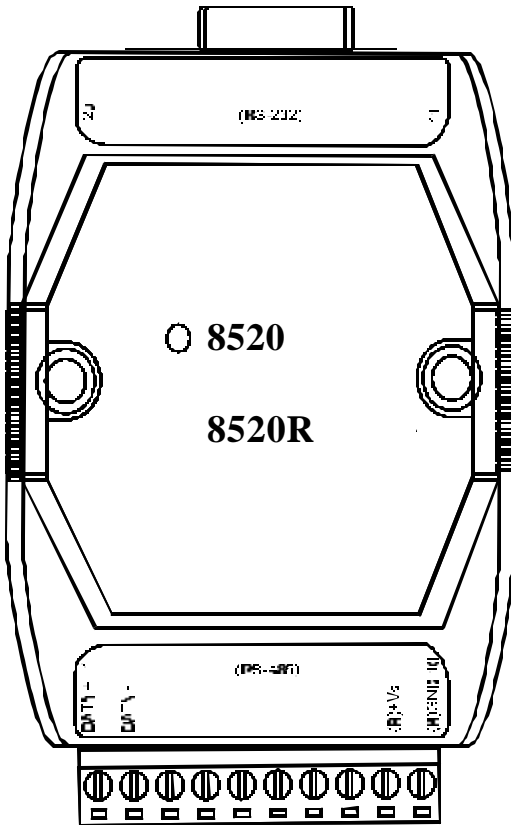

Figure 2.1.1 8520/8520R pin assignments

## 2.2 Specifications

### *8520: RS-232 to RS-485 Converter with isolation at RS-232 site*

**Protocol:** two-wire RS-485, differential (D+,D-)  
**Connector:** plug-in screw terminal block  
**Speed:** Internal "Self Tuner," automatic switching baud rate, from 1200 to 115200 BPS  
**Modules in Network:** 256 modules (max) in one RS-485 network without repeater  
2048 modules (max) in one RS-485 network with repeater  
**Isolation voltage:** 3000V  
**Isolation site:** RS-232  
**Repeater request:** 4,000 feet or over 256 modules  
**Power requirements:** +10V to +30VDC  
**Power consumption:** 2.2W(Max)

### *8520R : RS-232 to RS-485 Converter with Isolation at RS-485 site*

**Protocol:** two-wire RS-485, (D+,D-)  
**Connector:** plug-in screw terminal block  
**Speed:** Internal "Self Tuner," automatic switching baud rate, from 1200 to 115200 BPS  
**Modules in Network:** 256 modules (max) in one RS-485 network without repeater  
2048 modules (max) in one RS-485 network with repeater  
**Isolation voltage:** 3000V  
**Isolation site:** RS-485  
**Repeater request:** 4,000 feet or over 256 modules  
**Power requirements:** +10V to +30VDC  
**Power consumption:** 2.2W(Max)

## 2.3 Block Diagram

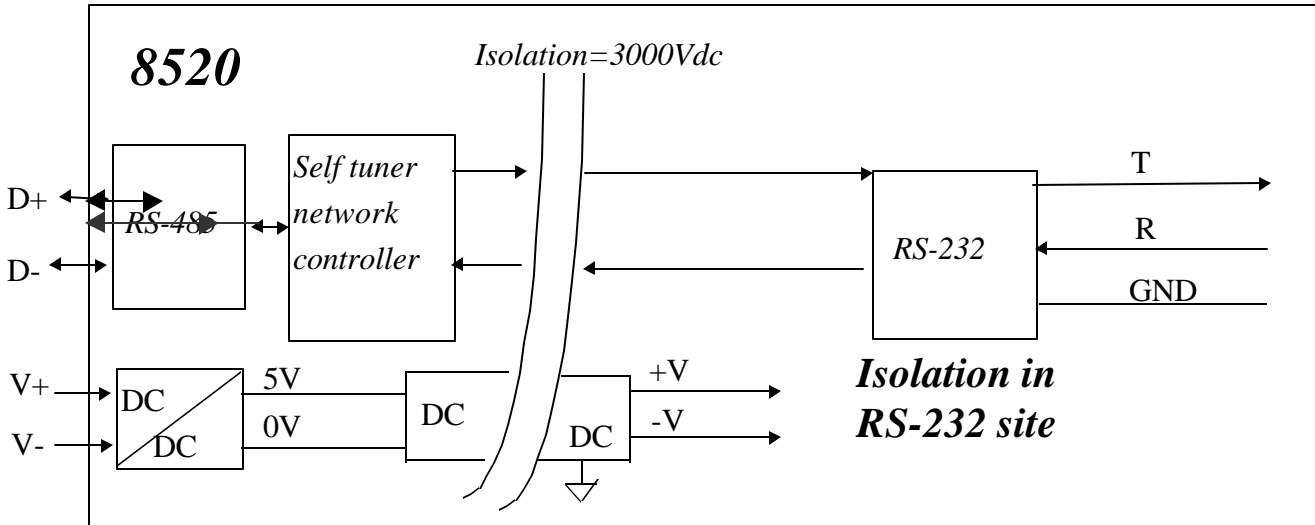

Figure 2.3.1 8520 block diagram

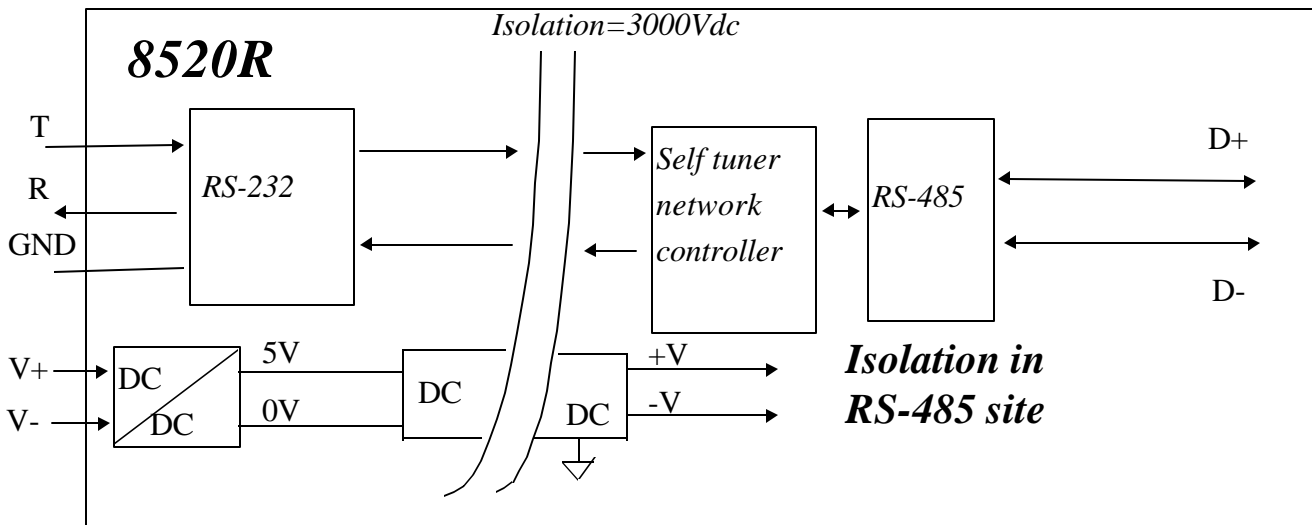

Figure 2.3.2 8520R block diagram

## 2.4 Basic Wire Connection

### RS 485 wire connections

GND ↔ Ext Power: GND  
 +VS ↔ Ext Power: 10-30V  
 Data- ↔ Data-  
 Data+ ↔ Data+

### RS 232 wire connections

Host (RXD) ↔ 8520\_pin2  
 Host (TXD) ↔ 8520\_pin3  
 Host (GND) ↔ 8520\_pin5

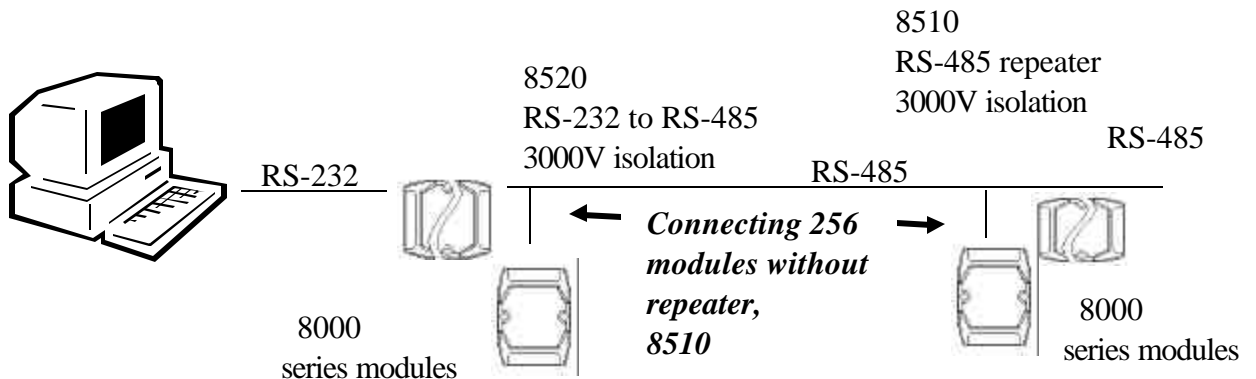
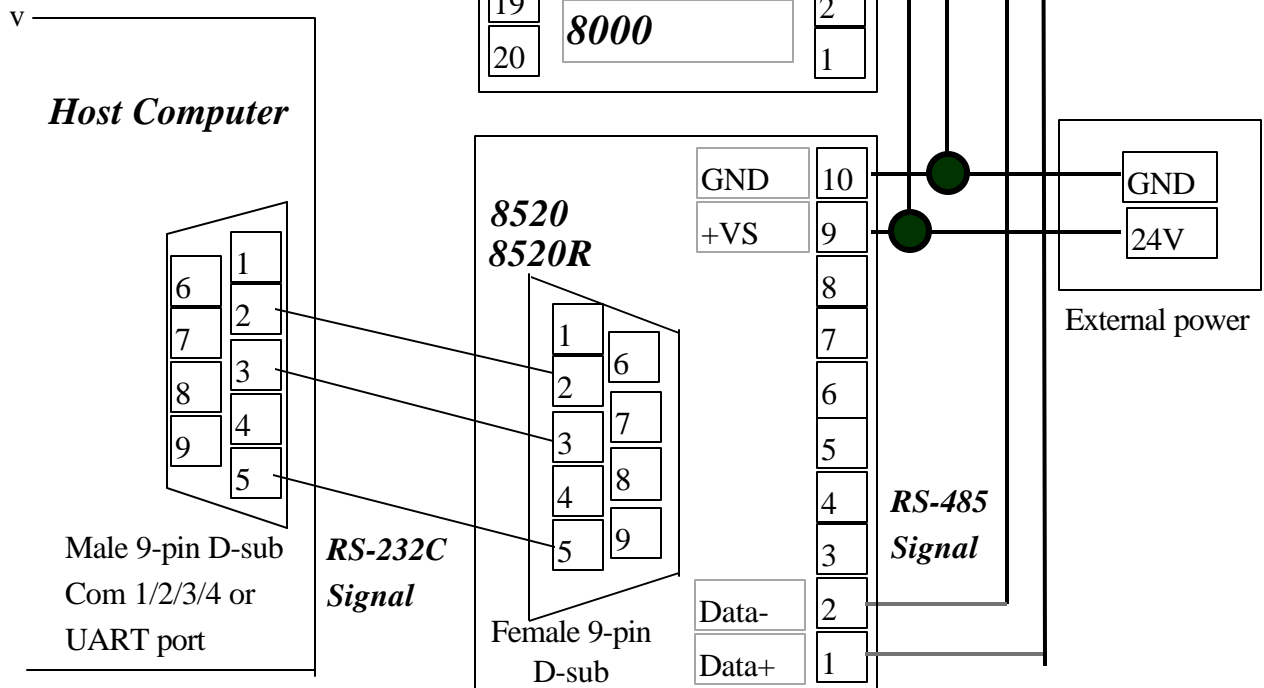

## 2.5 Choosing between 8520 and 8520R

8520R is exactly the same as 8520 except for the isolation site. The isolation site of the 8520 is located in the RS-232 interface circuit, but the isolation site of the 8520R is located in the RS-485 interface circuit. The power input and RS-485 interface is in common ground with 8520 but the power input and RS-232 interface is in common ground with 8520R. This is summarized in the table below.

	8520	8520R
RS-485 site	Common ground	Isolation site
Power ground		Common ground
RS-232 site	Isolation site	
Applications	Most applications	For RS-232 type PLC networking

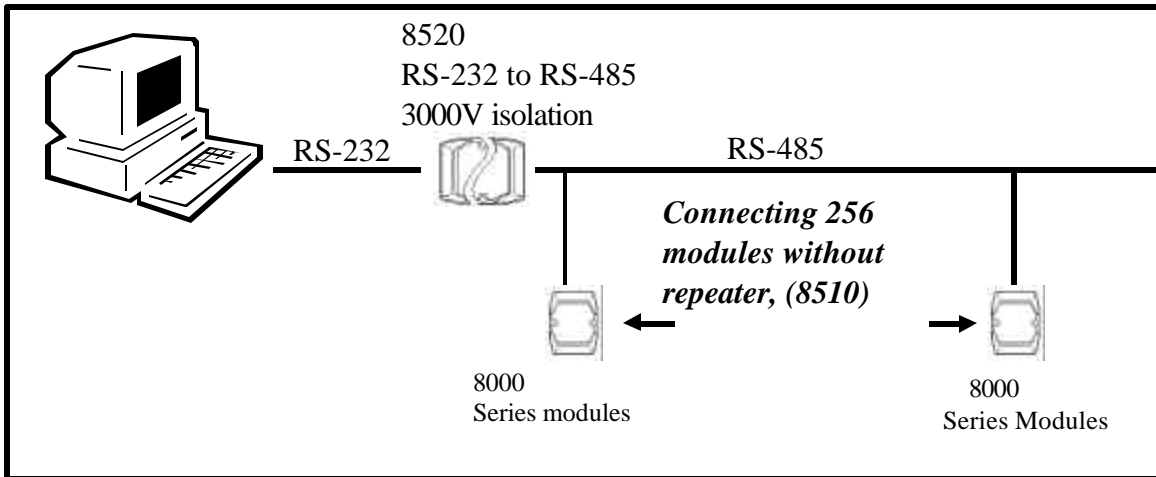

Figure 2.5.1 8520 Application

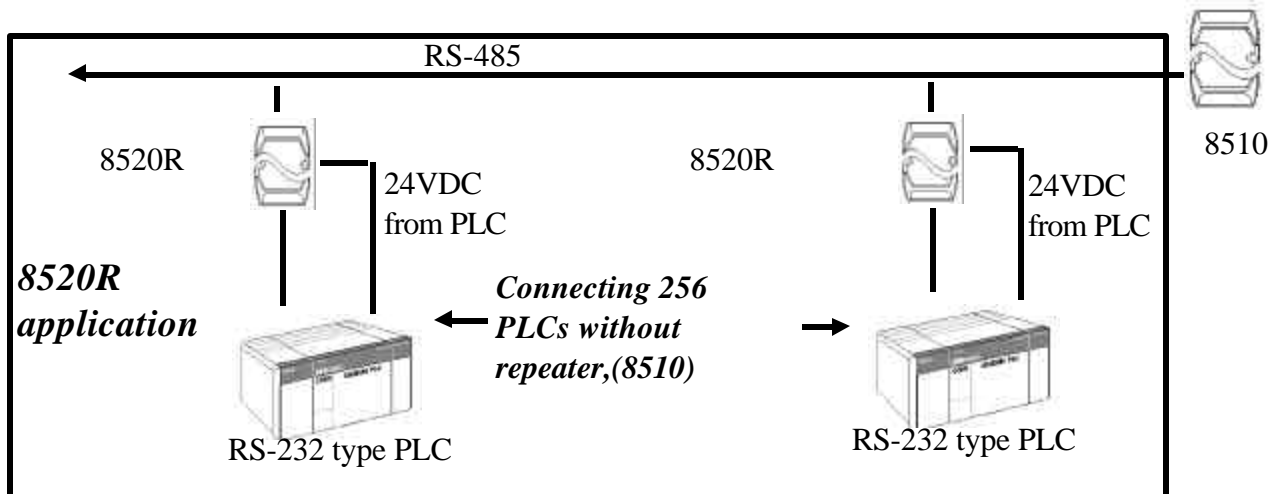
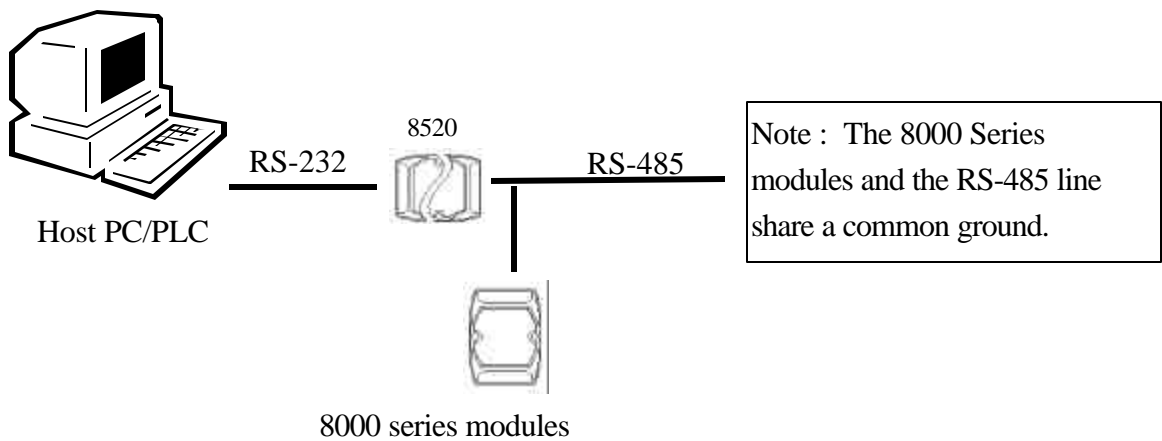

Figure 2.5.2 8520R application



*Figure 2.5.3 8000 Series Network with 8520 module*

In most applications, the 8520 is used to convert the RS-232 signal from the host PC for the RS-485 network, and vice versa. A system of this sort is depicted in *Figure 2.5.3*. Normally the 8520 does not use the same DC power ground as the Host PC/PLC, and the isolation site is at the RS-232 site, isolating the Host PC/PLC from the RS-485 network. With this configuration any high voltage transients on the RS-485 network would not effect the host PC/PLC.

**WARNING!! ERROR CONDITION 1:**

Referring to Figure 2.5.3 above, if the 8520 is replaced by the 8520R, and the 8520R uses the same DC power ground as do the 8000 modules, the following conditions are present:

- (1) The Host PC/PLC is in common ground with the RS-232 site
- (2) The RS-232 site is in common ground with 8520R power ground
- (3) The 8520R power ground is in common ground with the 8000 Series modules power ground
- (4) The 8000 Series modules share a common ground with the 8520R

In this situation, the Host PC/PLC shares a common ground with the RS-485 network, and there is no isolation between the Host PC/PLC and the RS-485 network. As the result, the Host PC/PLC may be damaged if there are any high voltage transients on the RS-485 network.

**WARNING!! ERROR CONDITION 2:**

If the 8520 has the same DC power ground as the Host PC/PLC (For example, the host PC/PLC provides a non-isolated DC power source to the 8520.), then the following conditions would be present:

- (1) The Host PC/PLC is in common ground with the 8520 power ground
- (2) The 8520 power ground is in common ground with the RS-485 network

In the above configuration, the Host PC/PLC shares a common ground with the RS-485 network, and there is no isolation between the Host PC/PLC and the RS-485 network. Therefore, the any high voltage transients on the RS-485 network may damage the Host PC/PLC.

**Proper Configuration:**

To ensure that the Host PC/PCL is completely isolated from the RS-485 network, make sure that the 8520/8520R DC power ground does not share a common ground with any other module in the network.

The PWR-24 24V DC power adapter can be used to provide isolated power to the 8520. However, it is designed for use with a single module only. The 24V DC output of the PWR-24 is isolated from its AC input. Thus, if 8520/8520R is connected to the PWR-24, then the PWR-24 can not connect to any other module. Normally the Host PC/PLC uses switching power. The DC output of this switching power supply is also isolated from its AC input. Therefore, since the Host and the 8520/8520R modules are using separate DC power grounds, the Host PC/PLC is completely isolated from the RS-485 network.

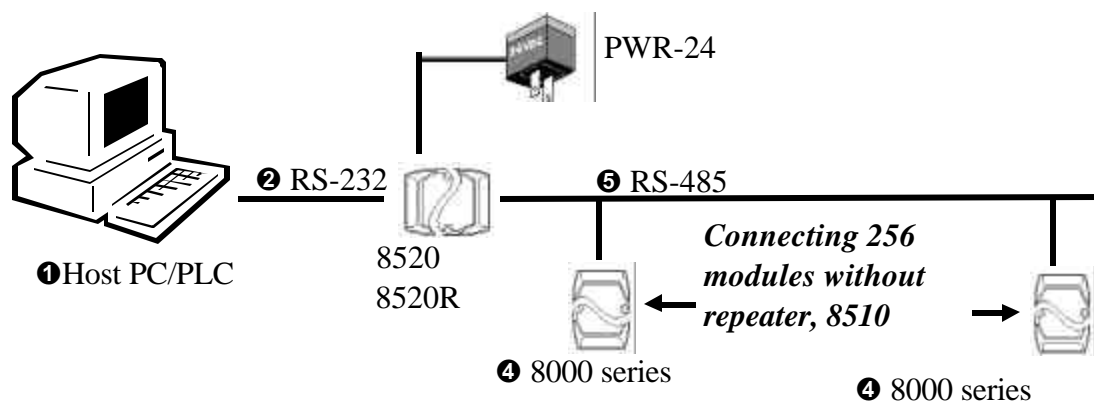

*Figure 2.5.4 Host PC/PLC and 8520/8520R use different DC power grounds, thus the Host is completely isolated from the RS-485 network.*



The 8520R is designed for PLC networking, and may share a 24 VDC power source with the PLC system (see configuration A in *Figure 2.5.5* below). If the 8520 module is used with the PLC system, and additional power source (PWR-24) is required (see configuration B in *Figure 2.5.5* below).

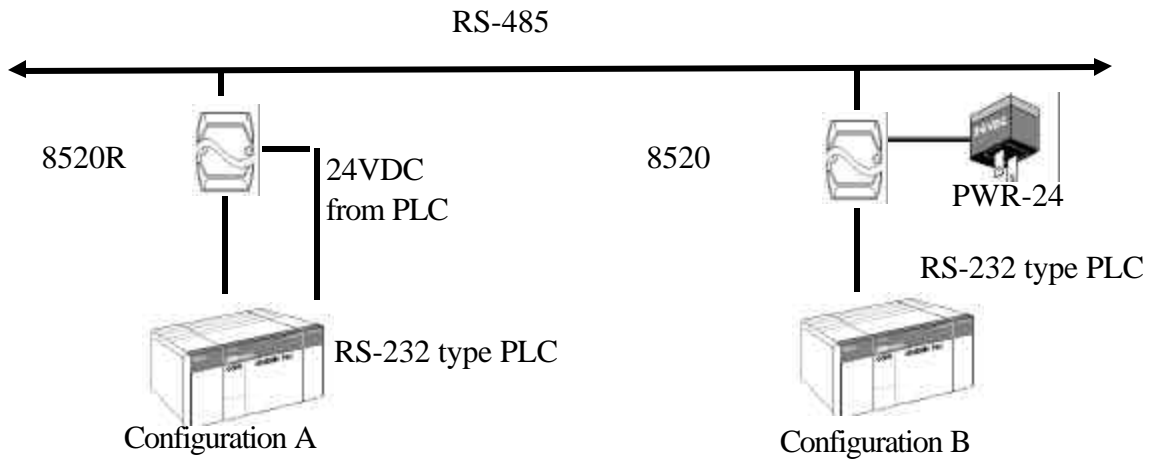

*Figure 2.5.5 8000 Series containing a RS-232 type PLC: 8520R vs. 8520*

Maintaining isolation between the Host PC/PLC and the 8000 RS-485 network is very important to ensuring system stability. Be certain to select the appropriate converter module for the network—8520 or 8520R. Even if the network is incorrectly grounded, the modules will continue to function normally, and if a high-energy transient occurs on the network, the Host can be severely and unexpectedly damaged.



Use the search function in the 8000Util program to locate the modules installed in the network, and determine their baud rate and address. (See the 8000Util manual for more information.)

All 8000 Series modules in an RS-485 network share a common ground. However, since this network can be up to 4000 feet long, it is highly susceptible to coupled noise. If transient energy causes too much noise, the entire network may be damaged. The 8510 module can be used to break a network up into smaller isolated segments. This way, if a portion of the line is damaged, it will not effect the entire system.

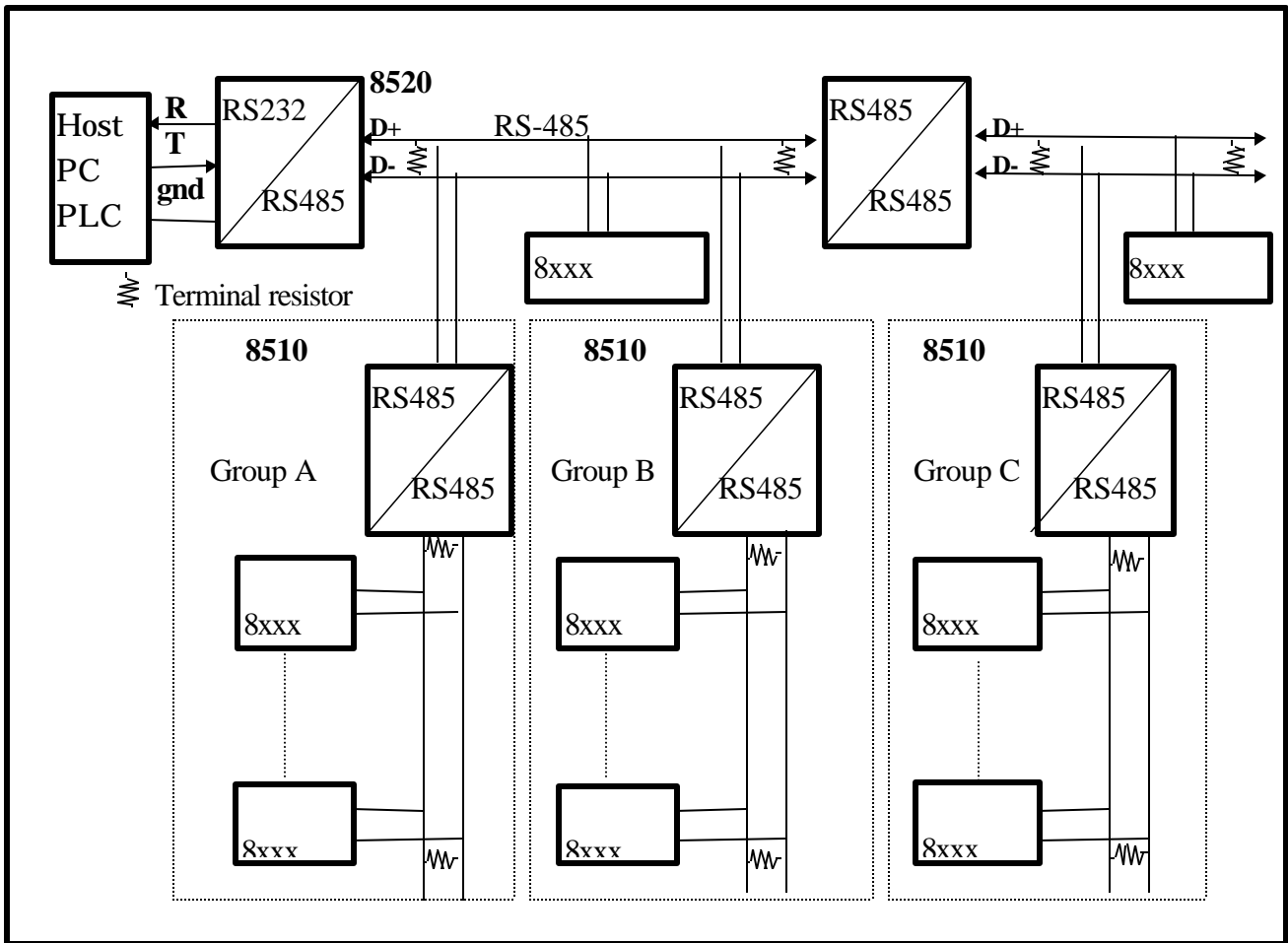
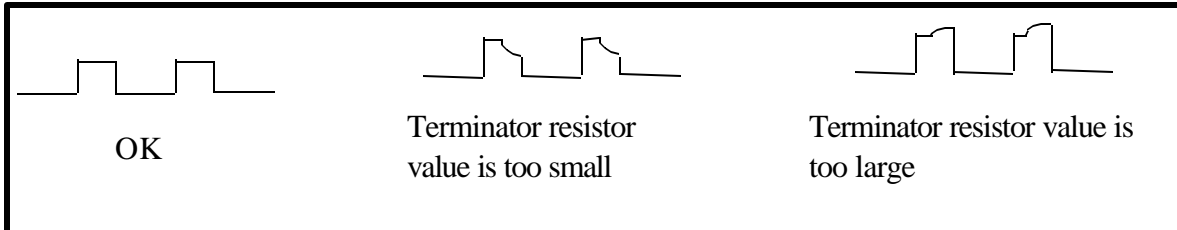

Figure 3.1.2 Isolated 8000 Network Configuration (Preferred)

For example, in Figure 3.1.2 above, the three 8510 modules are used to isolate local modules from the main RS-485 network. By creating several short RS-485 network paths with the repeaters protects all the modules from being damaged due to any high energy transients on the RS-485 network.

If the RS-485 network is under 328 feet, terminal resistors are not necessary in order for the system to function properly. However, if the network extends over 328 feet, terminal resistors may be required at both ends of the RS-485 segment. Calculating the value of the terminal resistor can be complicated, and the best method to use is “trial and error.” First use a scope to obtain the RS-485 signal reading. If the impedance match of RS-485 network is OK, the scope will illustrate a perfect square wave. If the squared wave is distorted, two terminal resistors should be inserted at both ends of the RS-485 segment. (See *Figure 3.1.3*)



*Figure 3.1.3 Scope readings for RS-485 signals*

To select the appropriate terminator resistor, try the following:

- (1) If the length of the RS-485 is approximately 4000 feet, begin with a 110 $\Omega$  resistor.  
If the length of the RS-485 is approximately 1970 feet, begin with a 220 $\Omega$  resistor.  
If the length of the RS-485 is approximately 980 feet, begin with a 330 $\Omega$  resistor.
- (2) Use 8000Util to select the module and run communication for an eight hour period.
- (3) If 8000Util returns numerous communication errors, use a scope to check the waveform. Depending on whether the scope shows that the terminal resistor is too small or too large (see figure 3.1.2 above) change the resistor and perform another 8 hour test..
- (4) When the appropriate resistor values are determined, run the communication test for one more uninterrupted eight hour stretch.

The 8000Util will continuously perform “send and receive testing”. When testing, all test results are recorded. This function is particularly useful for evaluating a network’s stability. If the system can run for eight hours with no errors, it can be assumed that the system is stable and the correct terminal resistor has been selected.

**NOTE 1:** The value of terminal resistor depends upon the type of RS-485 wire used. If the RS-485 path is long, a high quality wire is preferable.

**NOTE 2:** The terminal resistor varies from application to application. Therefore, the 8520 and 8510 are not equipped with terminal resistors. The user must select and provide the terminal resistors. (Carbon, 1/4W resistor terminators are recommended.)

## 3.2 PLC Networking Applications

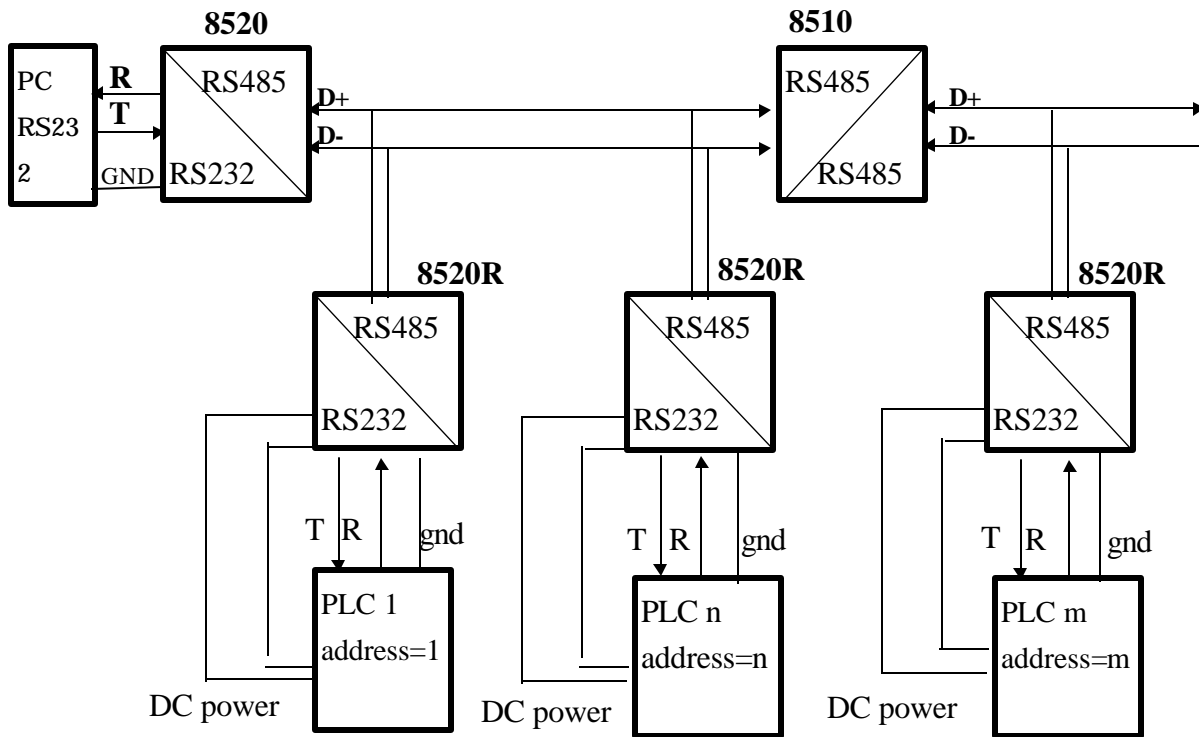

Figure 3.2.1 PLC Networking Application

The 8000 Series can operate in an RS-485 network with multiple PLCs which use different baud rates and different data formats. For example, in Figure 3.2.1, the three PLCs in the system are configured as follows:

PLC-1 = 1 start + 7 data + 1 stop = 9-bit/word, baud rate =1200

PLC-n = 1 start + 8 data + 1 parity + 1 stop= 11-bit/word, baud rate=9600

PLC-m = 1 start + 8 data + 1 parity + 2 stop= 12-bit/word, baud rate=115200

**OMRON CQM1 = 1 start + 7 data + 1 even parity + 2 stop = 11-bit/word**  
**OMRON C200 = 1 start + 7 data + 1 even parity + 2 stop = 11-bit/word**

Either the 8520 or 8520R can be used as the converter module for this system. Similarly, the additional converter modules used in the network can be either the 8520 or 8520R. The system illustrated in Figure 3.2.1 uses a 8520 module to make the connection to the host PC and three 8520R modules to connect with the three PLCs. Because the PLCs are providing DC power to the three converter modules, it is important that 8520R modules be used to maintain 3000V high isolation. (See section 2.5 for more information about module isolation.)

### 3.3 PC Networking Applications

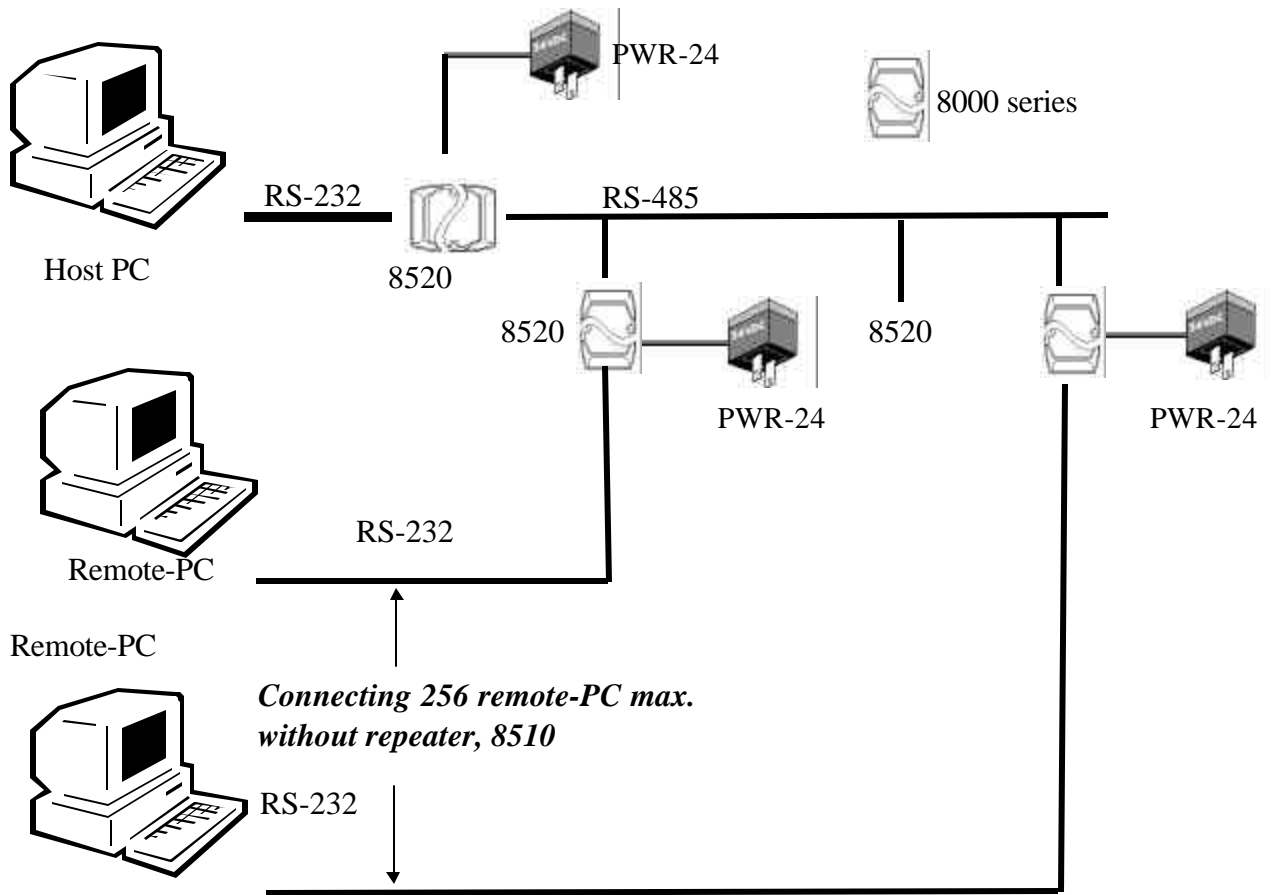

Figure 3.3.1 8000 Series Network incorporating remote PCs

Every remote PC in a network has a unique address known as a “slave PC address”. Similar to the module address of the 8000 series, the slave PC address is unlimited. Any number of remote PCs can be connected in a single RS-485 network environment by using the 8510 repeater. The host PC sends out a command to the remote PC using the same method it uses to send commands to 8000 Series modules. When the remote PC receives a command, it first determines whether the command was addressed to it—if it is, the command is executed; if it is not, the command is ignored.

### 3.4 RS-232 Device Network

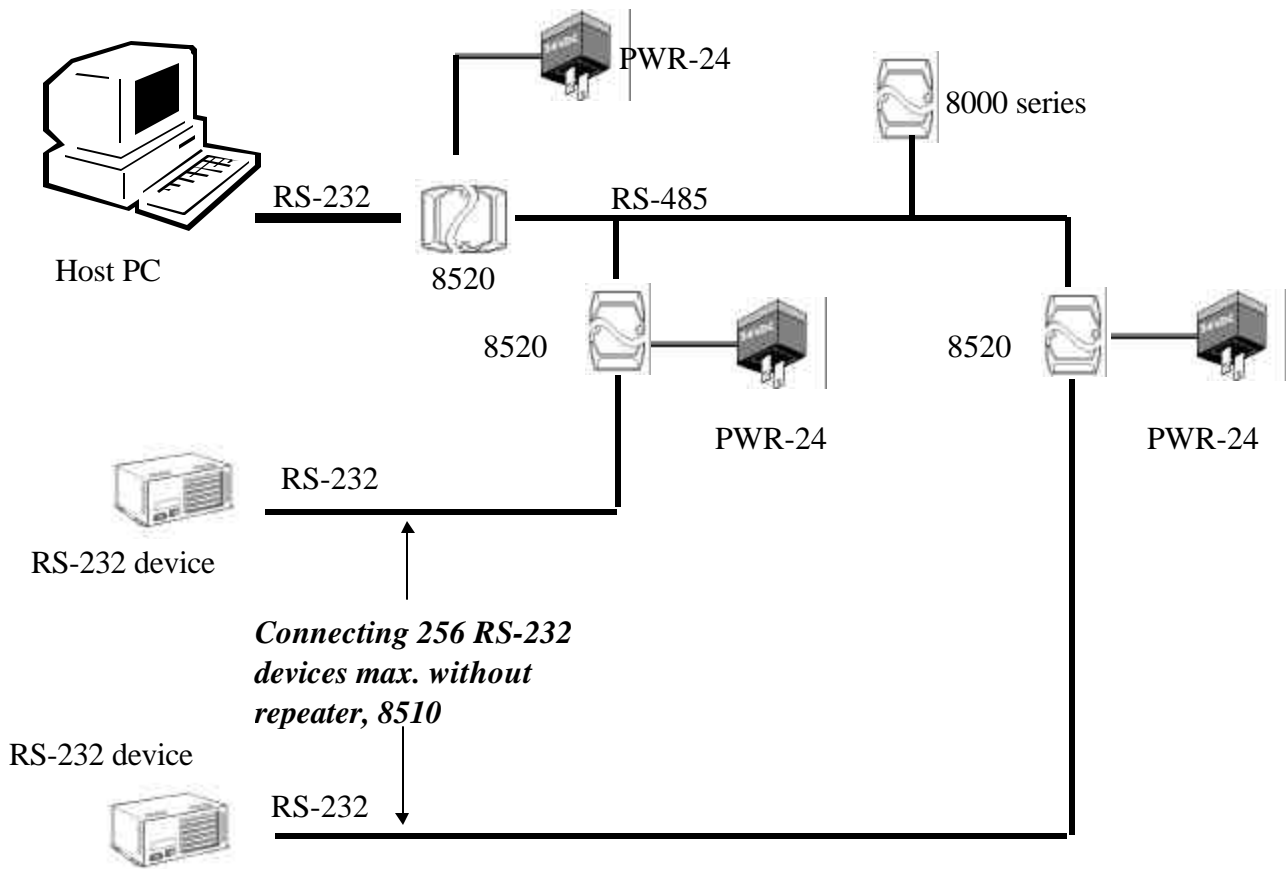

Figure 3.3.1 8000 network incorporating multiple RS-232 devices

RS-232 devices can be easily connected to a 8000 Series RS-485 network in the same manner as the PC or PLC connection. These RS-232 devices must follow the rules below:

- Rule 1 :** The RS-232 device can not send out a RS-232 signal in the normal condition
- Rule 2 :** Every device must have a unique device address
- Rule 3 :** The RS-232 device does not send out a RS-232 signal if the destination address does not match with the device address

In order to connect RS-232 devices to the network, a 8520/R module must be used to convert the RS-232 signal to RS-485 and vice versa. For more information on the necessary software programming for RS-232 serial devices, refer to 8000 software manuals.